

FRETURE

EMISSION FREE PROCESS

SEALED FOR SAFETY

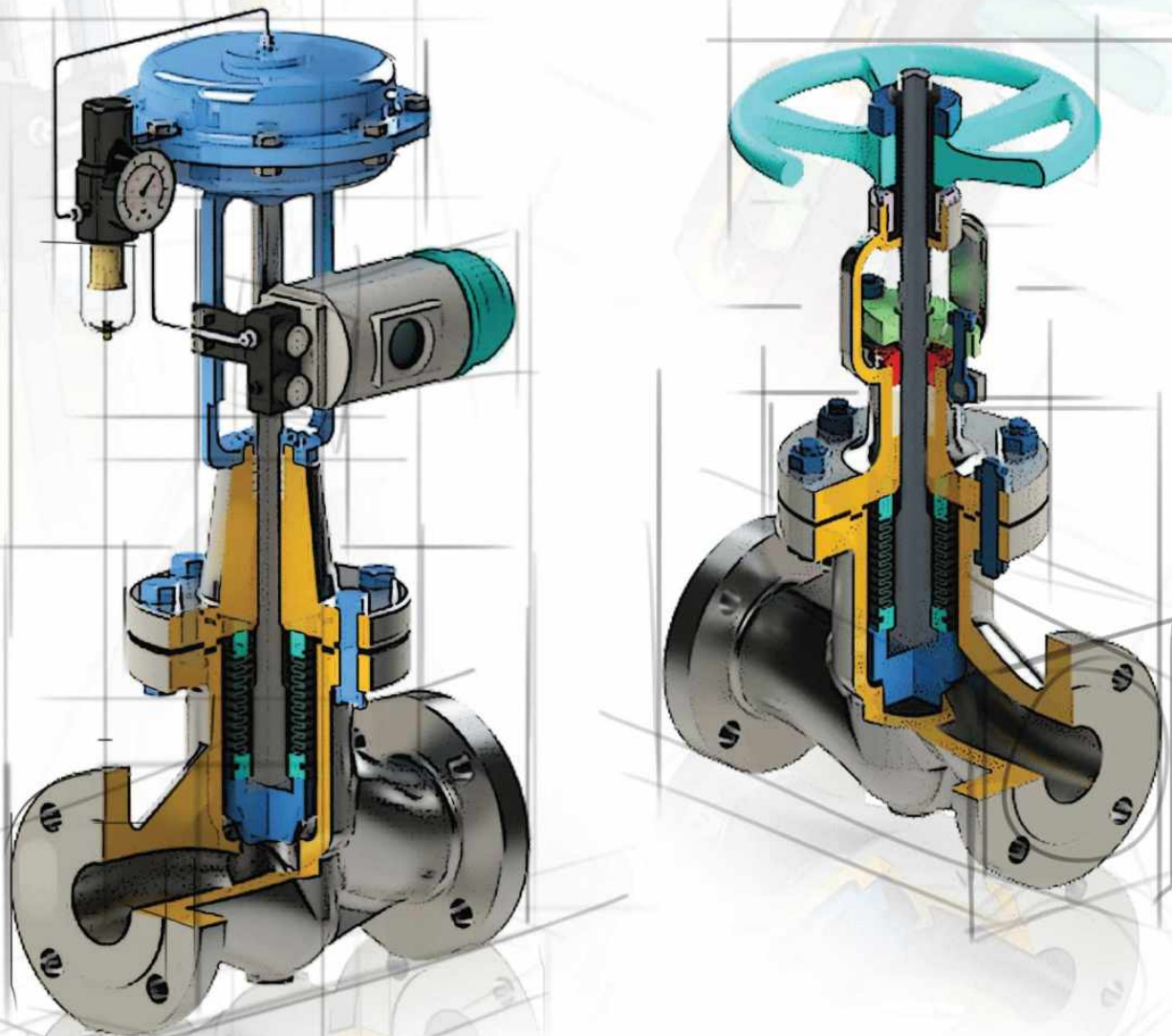

INNOVATION FOR SUSTAINABILITY

BELLOW - SEAL VALVE

www.freture.com

ISO 9001 - 15000 | ISO 14000 | ISO 45001 | PED 2014 / 68 / EU

ABOUT US

Freture Techno, a prominent precision valve manufacturer with 15 years of experience, prioritizes excellence, a prominent precision valve manufacturer with 15 years of experience, prioritizes excellence in every aspect of their work. Our valves, crafted by skilled professionals by making Sustainability a central theme, as they strive to minimize environmental impact through efficient manufacturing, ensuring exceptional products while reducing resource consumption and waste in every aspect of their work. Our valves, crafted by skilled professionals by taking Sustainability in a central theme, as they strive to minimize environmental impact through efficient manufacturing, ensuring exceptional products while reducing resource consumption and waste.

With a diverse clientele spanning Oil, Gas, pharmaceuticals, chemicals, petrochemicals, and food industries, Freture Techno exhibits versatility and adaptability to dynamic sector needs. As the company continues to innovate, they remain committed to providing sustainable Valve & Piping solutions that align with the evolving demands of clients globally.

VISION

Our vision is clear to provide precision products and services that enhance and strengthen relationships with our clients. We aspire to be the leading provider of valve solutions, renowned for our unwavering commitment to quality, reliability, and customer satisfaction.

Our vision is not just about delivering products; it's about fostering trust, reliability, and mutual growth in every interaction.

MISSION

At Freture Techno, our mission is to serve our precision products and services on a global scale, supporting industries in maintaining their critical flow processes. We are dedicated to providing innovative valve solutions that optimize efficiency and sustainability for our customers worldwide.

We ensure that every client, regardless of location or industry, can count on Freture Techno to deliver the products and support they need to thrive.

INDEX

1

ABOUT BELLOW SEAL VALVE

2

WHY BELLOW SEAL VALVES?

3

BELLOW SEAL GLOBE VALVES

4

BELLOW SEAL GATE VALVES

5

FORGED BELLOW SEAL VALVE
(GATE / GLOBE)

6

EURO-CHLOR
BELLOW SEAL VALVES

7

BELLOW SEAL
GLOBE EXTERNAL STEM

8

BELLOW SEAL
CONTROL VALVES

9

INDUSTRIES & APPLICATION

10

INDUSTRIES & APPLICATION

11

CALCULATION OF CV

12

BELLOW SEAL VALVES &
ECONOMICS

13

BELLOW SEAL VALVES &
ECONOMICS

14

BELLOWSEAL VALVE TESTING

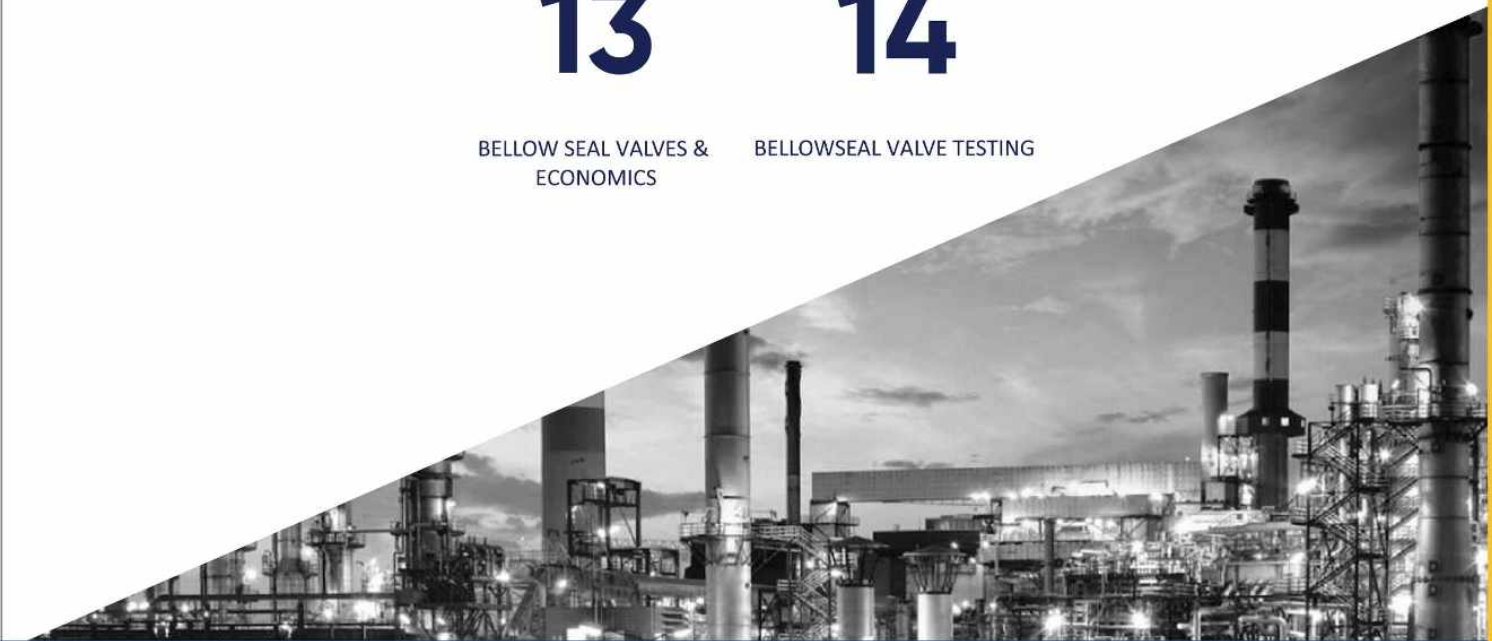

ABOUT BELLOW SEAL VALVE

Bellow Sealed Valves are a unique technology Industrial valves that are meant to provide zero valve leakage. They are also known as Glandless "Emission Free Valves".

A metallic Bellow Assembly is welded to the valve bonnet at one end and the stem at the other end of these valves, supplementing standard gland packing. The Bellow expands or contracts in response to the valve stem's stroke action (Open/Closed). There are no sliding or rotating seals allowing process fluid to pass through.

As a result, the fluid will enter the valve through the seat and make contact with the bellow but not the stem and amp; Gland Seal. Because the stem is the only moving portion in the valve, continual friction induced by axial movement makes it a possible source of leakage into the gland.

In a Bellows sealed valve, this possible leak is fully avoided because the metallic Bellow effectively stops the leak channel by not allowing the media to come into touch with the stem and hence the gland. A Bellow is at the core of this Bellow Seal valve.

A tiny drop of 0.4 mm diameter/sec wastes approximately 200 L/yr of expensive oil or solvent. This equates to a loss of approximately \$1,200 per year of a commonly used heating fluid such as Dowtherm and all for a \$100 valve!!!

ORDINARY VALVE
(Observe Leakage Through Gland)

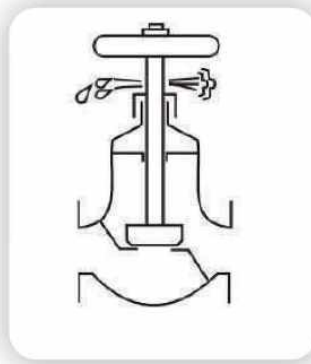

BELLOW SEALED VALVE
(Gland Shut-Off With Metallic Bellows)

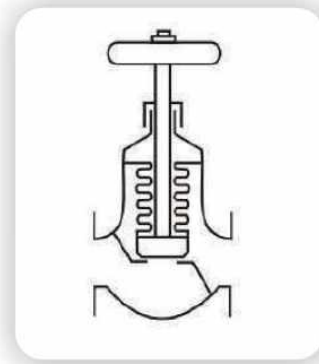

There are two types of bellows: FORMED LEAF AND WELDED LEAF

TYPE	FORMED BELLOWS	WELDED BELLOWS
Shape of Convolution		
Durability	Reliable durability because bellows are produced from a single piece of metal. Guaranteed 10,000 cycles or more life cycle.	Of doubtful reliability because of a number of welded joints. Pliers can be affected by heat and thus cycle life is hard to predict.
Suitability for use in Valve	Because of wide opening between plies of bellows, bellow compression function will not be impaired by bits of foreign matter in fluid.	Wedge-shaped opening between plies will trap foreign matter in fluid, leading to bellow failure.
Quality Control	Easy to test for quality, bellow can be produced with uniform quality.	Very difficult to inspect welded spots for quality, hence quality difficult to control.

WHY BELLOWS SEAL VALVES?

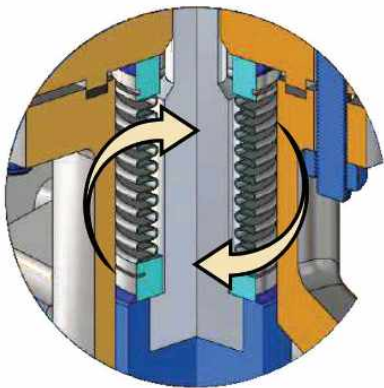

No Bellow Torsion

The non-rotating stem prevents Bellows Torsion and guarantees high cycle life Bellows-Seal Valves.

Minimal Torque

Because of the non-rotating stem, a central grease fitting is used to lubricate the stem nut and for high-pressure valves, a stem thrust bearing.

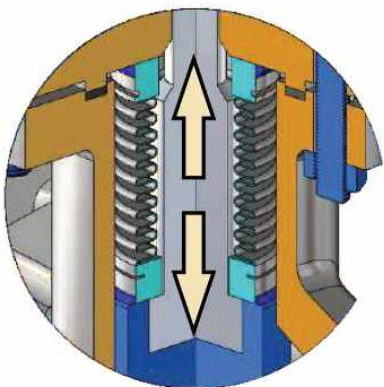
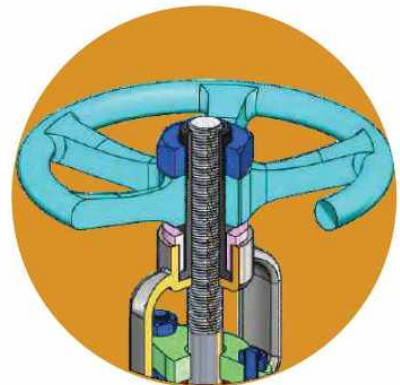

Bellows with long cycle life

Designed for High Pressure/Temperature applications and successfully tested as per MSS SP-117/API 598.

Secondary Gland Seal

- A. When open the backseat (stem bevel) guards against line pressure.
- B. Gland Packing (Graphite/PTFE).

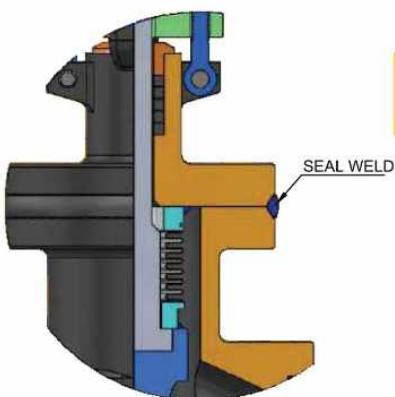
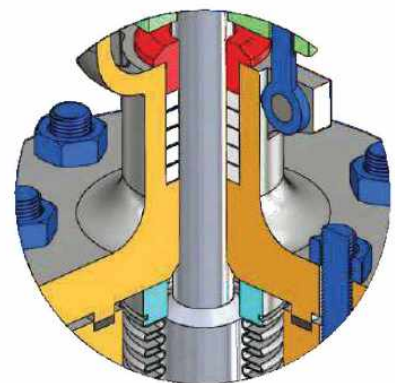

Hermetically Sealed (100% Emission Free)

- A. In most designs, Body-Bonnet welds create a hermetically sealed vessel. (As per requirement)
- B. Operating and maintenance costs are significantly decreased as a result of the longer service life.

BELLOW SEAL GLOBE VALVES

A Bellows Seal Globe Valve is a type of control valve that is a kind of control valve that seals the valve stem components using bellows. A Bellows is contained within the valve, and the lower end of the stainless-steel / Nickel Alloy Bellows is welded to the stem to prevent the stem from being eroded by system fluid. The other end is inserted between the valve's body and cover to form a permanent seal. This double seal structure prevents leakage; in the event that the bellows collapse, the stem packaging will prevent further leakage. The bellows are welded to the valve stem to provide steady operation and to eliminate valve stem vibration caused by the valve insert movement.

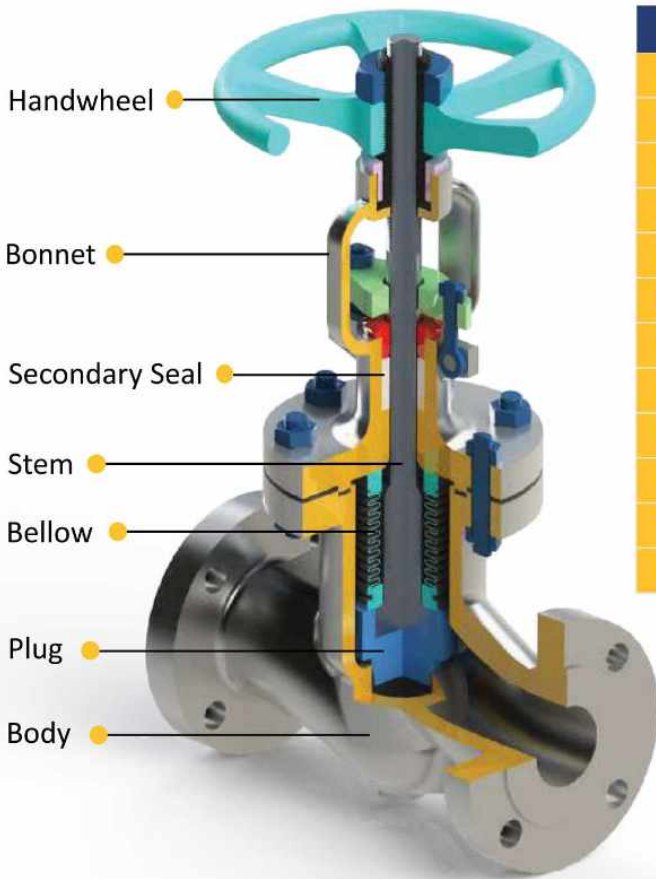

SPECIFICATIONS	
End Connection:	Flange (B16.5) / Butt Weld (B16.25)
Size :	15 NB - 600 NB
Pressure Rating:	#150 - #1500
Temperature:	-190°C to 350°C
MOC :	Carbon Steel / Stainless Steel / Alloy
Design Standard:	MSS SP-117 / API 623
Cycle Life :	3000 - 5000 - 10000 Life Cycle
Face to Face:	ASME B16.10 Rev 2009
Operating:	Manual / Gear / Actuated
Fire safe design:	API 6FA
Testing:	API 598 Rev 2009 / ISO 15848
Documents:	BS/EN 10204-3.1 REV 2019

Size		Face To Face (F)				Center Height (H)		Flange Weight (KG)		Butt-Weld Weight (KG)	
		RF		RTJ							
Inch	NB	#150	#300	#150	#300	#150	#300	#150	#300	#150	#300
1/2"	15NB	108	152	-	163	250	260	5	6	5	5
3/4"	20 NB	117	216	-	229	250	320	7	23	6	6
1 1/2"	40 NB	165	229	178	242	330	390	18	26	16	22
2	50 NB	203	267	216	283	410	420	22	31	19	27
2 1/2"	65 NB	216	292	229	308	432	435	30	48	26	41
3"	80 NB	241	318	254	334	450	450	42	58	36	50
4"	100 NB	292	356	305	372	500	520	60	86	51	73
6"	150 NB	406	444	419	460	550	650	101	150	86	128
8"	200 NB	495	559	508	575	620	800	161	397	137	338
10"	250 NB	622	622	635	638	762	1040	308	527	262	448
12"	300 NB	698	711	711	727	860	1140	410	608	349	517

BELLOW SEAL GATE VALVES

A Bellows Seal Gate Valve is a construction that is a kind of Std. API Extended Stem Gate Valve that seals the valve stem components using bellows. A Bellows is contained within the valve, and the lower end of the stainless-steel/Nickel Alloy Bellows is welded to the stem to prevent the stem from being eroded by system fluid. The other end is inserted between the valve's body and cover to form a permanent seal. This double seal structure prevents leakage; in the event that the bellows collapse, the stem packaging will prevent further leakage. The bellows are welded to the valve stem to provide steady operation and to eliminate valve stem vibration caused by the valve insert movement.

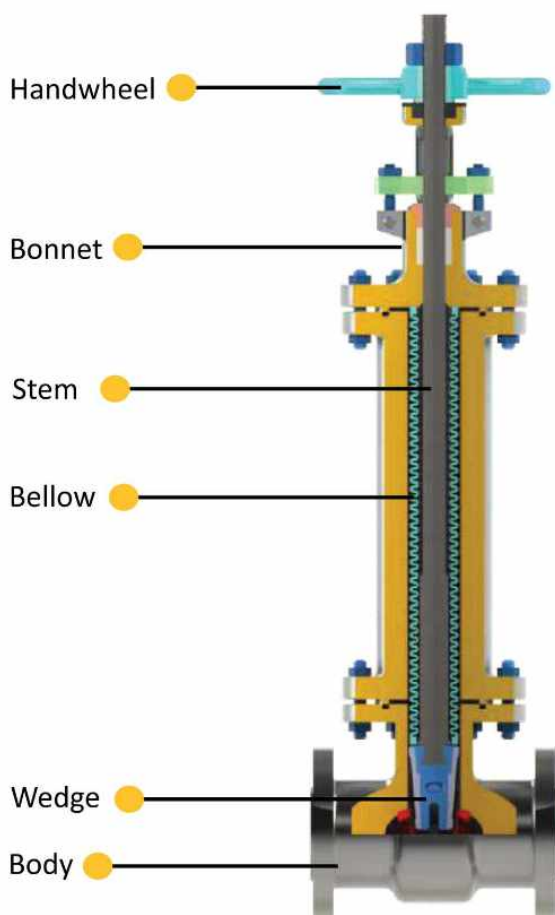

SPECIFICATIONS	
End Connection:	Flange (B16.5) / Butt Weld (B16.25) / Socket Weld (B-16.11)
Size :	15 NB - 600 NB
Pressure Rating:	#150 - #1500
Temperature:	-190°C to 350°C
MOC :	Carbon Steel / Stainless Steel / Alloy
Design Standard:	MSS SP-117 / API 600 / API 602
Cycle Life :	3000 - 5000 - 10000 Cycle
Face to Face:	ASME B16.10 Rev 2009
Fire safe design:	API 6FA
Testing:	API 598 Rev 2009 / ISO 15848
Documents:	BS/EN 10204-3.1 REV 2019

Size		Face-to-Face (F)				Centre Height (H)	Flange Weight (KG)		Butt-Weld Weight (KG)		
		RF		RTJ			#150	#300	#150	#300	
Inch	NB	#150	#300	#150	#300	#150	#300	#150	#300	#150	#300
1/2"	15NB	108	140	-	151	297	307	6	7	5	6
3/4"	20 NB	117	152	-	165	312	327	8	8	6	6
1 1/2"	40 NB	165	190	178	203	410	470	20	30	17	25
2	50 NB	178	216	191	232	515	525	21	28	17	23
2 1/2"	65 NB	190	241	203	257	555	558	32	51	26	43
3"	80 NB	203	282	216	298	608	608	39	60	32	51
4"	100 NB	229	305	242	321	825	895	59.8	87	51	74
6"	150 NB	267	403	280	419	1107	1224	101	168	85	143
8"	200 NB	292	419	305	435	1410	1570	116	251	140	213
10"	250 NB	330	457	343	473	1802	1920	227	405	192	344
12"	300 NB	356	502	369	518	2054	2292	343	549	219	461

FORGED BELLOW SEAL VALVE (GATE/GLOBE)

A Forged Bellows Seal Gate/Globe Valve is a construction that is a kind of Forging Body and Bonnet that seals the valve Gland using Bellows. A Bellows is contained within the valve, and the lower end of the stainless-steel/Nickel Alloy Bellows is welded to the stem to prevent the stem from being eroded by system fluid. The other end is inserted between the valve's body and cover to form a permanent seal. This double seal structure prevents leakage; in the event that the bellows collapse, the stem packaging will prevent further leakage. The bellows are welded to the valve stem to provide steady operation and to eliminate valve stem vibration caused by the valve insert movement.

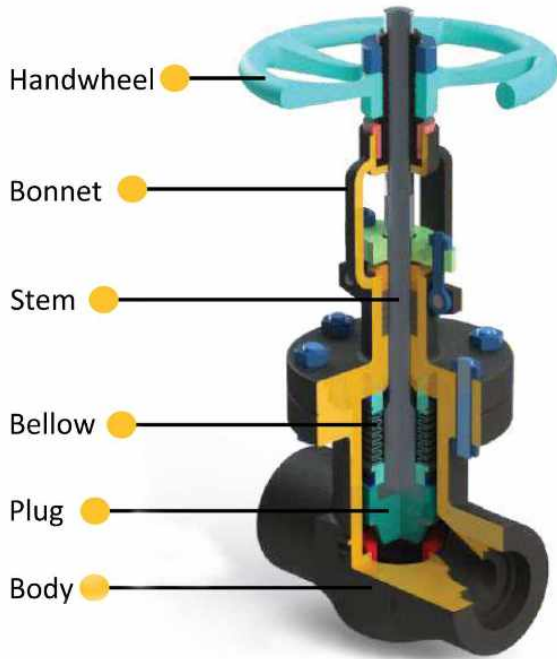

Size		Face-to-Face (F-F)		Center Height (H)		Weight Flange (Kg)	
Inch	NB	#150	#1500	#800	#300	#800	#300
1/2"	15 NB	84	97	150	173	2	3
3/4"	20 NB	90	104	162	186	2	3
1 1/2"	40 NB	165	190	249	287	10	15
2"	50 NB	178	204	281	323	11	18

SPECIFICATIONS	
Type:	Globe Valve / Gate Valve
End Connection:	Socket Weld (B-16.11) / Thread (BSP / NPT)
Size :	15 NB - 50 NB
Pressure Rating:	#800 - #1500
Temperature:	-190°C to 350°C
MOC :	Carbon Steel / Stainless Steel / Alloy
Design Standard:	MSS SP-117 / API 600
Cycle Life :	3000 - 5000 - 10000 Cycle
Face to Face:	Manufacturer Std
Fire safe design:	API 6FA
Testing:	API 598 Rev 2009 / ISO 15848
Documents:	BS/EN 10204-3.1 REV 2019

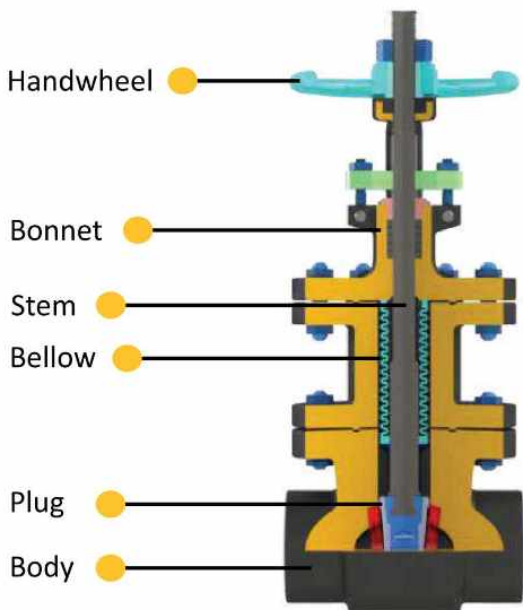

SIZE		Face-to-Face (F-F)		Center Height (H)		Weight Flange (Kg)	
Inch	NB	#150	#1500	#800	#300	#800	#300
1/2"	15 NB	84	118	154	183	2	4
3/4"	20 NB	90	109	164	192	2	4
1 1/2"	40 NB	121	141	263	295	7	12
2"	50 NB	130	151	298	336	9	14

EURO-CHLOR BELLOW SEAL VALVES

Euro-Chlor Bellows Seal Globe Valve- featuring ASME B 16.5 flanges, ASME B 16.10 face-to-face flanges, ACME stem screw thread, and grounded shaft. Multiple wall liquid protected bellows built of Hastalloy C 276 with a minimum life cycle of 10,000 cycles, metal back seat, PTFE safety stuffing box packing, Stainless steel spiral wound bonnet gasket with PTFE filler material and housed in a tongue and grooved flange. Valve was tested in accordance with EURO CHLOR GEST 89/140.

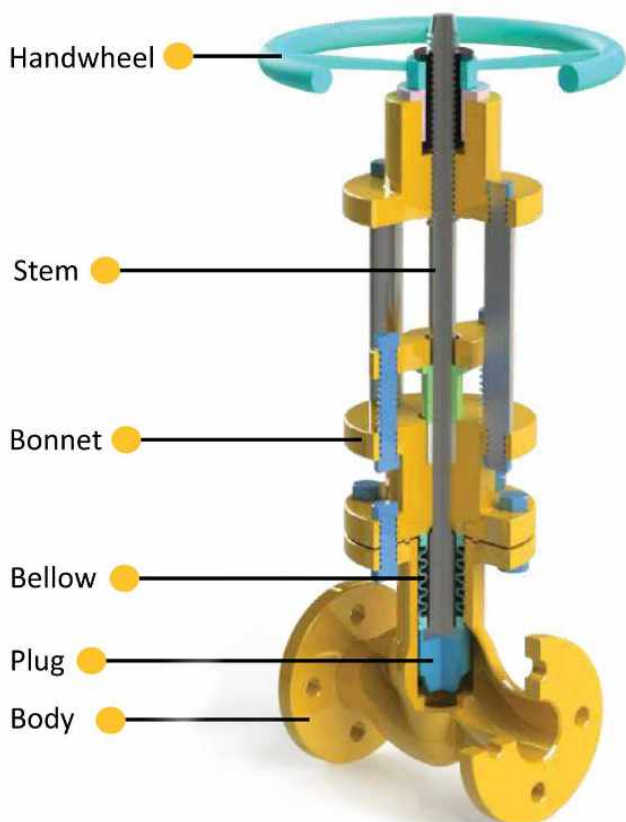

SPECIFICATIONS	
End Connection:	Flange (B16.5) / Butt Weld (B16.25)
Size :	15 NB - 600 NB
Pressure Rating:	#150 - #900
Temperature:	-190°C to 350°C
MOC :	Carbon Steel / Stainless Steel / Alloy
Design Standard:	MSS SP-117 / API 623
Cycle Life :	3000 - 5000 - 10000 Cycle
Face to Face:	ASME B16.10 Rev 2009
Fire safe design:	API 6FA
Testing:	API 598 Rev 2009 / ISO 15848
Documents:	BS/EN 10204-3.1 REV 2019

Size		Face To Face (F)				Center Height (H)		Flange Weight (KG)		Butt-Weld Weight (KG)	
		RF		RTJ							
Inch	NB	#150	#300	#150	#300	#150	#300	#150	#300	#150	#300
1/2"	15NB	108	152	-	163	300	312	6	7	5	6
3/4"	20 NB	117	216	-	229	300	318	8	8	6	7
1 1/2"	40 NB	165	229	178	242	396	468	20	29	18	24
2	50 NB	203	267	216	283	492	504	24	34	21	30
2 1/2"	65 NB	216	292	229	308	518.4	522	33	53	29	45
3"	80 NB	241	318	254	334	540	540	46	64	40	55
4"	100 NB	292	356	305	372	600	624	66	95	56	80
6"	150 NB	406	444	419	460	660	780	111	165	95	141
8"	200 NB	495	559	508	575	744	960	177	437	151	372
10"	250 NB	622	622	635	638	914.4	1248	339	580	288	493
12"	300 NB	698	711	711	727	1032	1368	451	669	384	569

BELLOW SEAL GLOBE VALVE - EXTENDED STEM

A Extended Stem Bellows Seal Globe Valve is a construction of Globe/Gate Valve that seals the valve stem components using bellows. A Bellows is contained within the valve, and the lower end of the stainless-steel / Nickel Alloy Bellows is welded to the stem to prevent stem corrosion by system fluid. The other end is inserted between the valve's body and cover to form a permanent seal. This double seal structure prevents leakage; in the event that the bellows collapse, the stem packaging will prevent further leakage.

The bellows are welded to the valve stem to provide steady operation and to eliminate valve stem vibration caused by the valve insert movement.

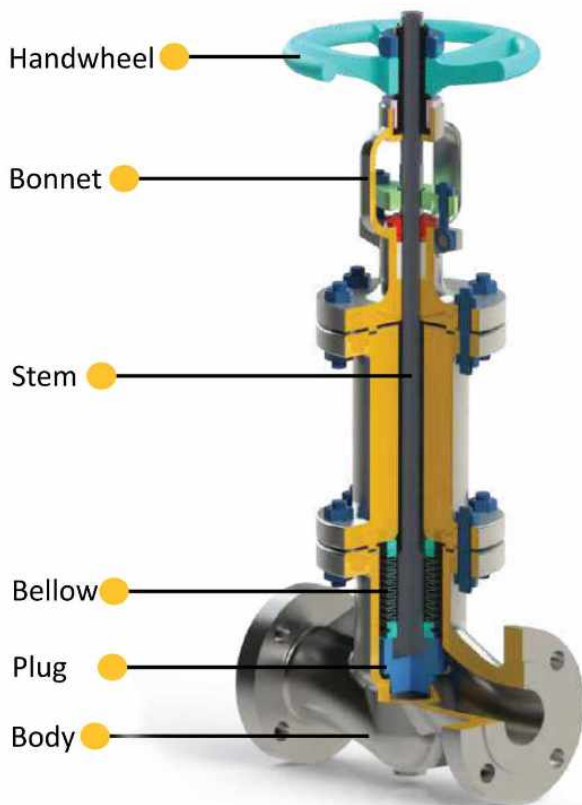

SPECIFICATIONS	
End Connection:	Flange (B16.5) / Butt Weld (B16.25)
Size :	15 NB - 600 NB
Pressure Rating:	#150 - #900
Temperature Range: -	-190°C to 350°C
MOC :	Carbon Steel / Stainless Steel / Alloy
Design Standard:	MSS SP-117 / API 623 / API 600 / API 602
Cycle Life :	3000 - 5000 - 10000 Cycle
Face to Face:	ASME B16.10 Rev 2009
Fire safe design:	API 6FA
Testing:	API 598 Rev 2009 / ISO 15848
Documents:	BS/EN 10204-3.1 REV 2019

Size		Face To Face (F)				Centre Height (H)		Flange Weight (Kg)		Butt-Weld Weight (Kg)	
		RF		RTJ							
Inch	NB	#150	#300	#150	#300	#150	#300	#150	#300	#150	#300
1/2"	15NB	108	152	-	163	350	360	6	7	6	6
3/4"	20 NB	117	216	-	229	350	365	8	8	7	7
1 1/2"	40 NB	165	229	178	242	430	490	20	29	18	24
2"	50 NB	203	267	216	283	510	520	24	34	21	30
2 1/2"	65 NB	216	292	229	308	532	535	33	59	29	45
3"	80 NB	241	318	254	334	600	600	46	64	40	55
4"	100 NB	292	356	305	372	650	670	66	95	56	80
6"	150 NB	406	444	419	460	700	800	111	165	95	141
8"	200 NB	495	559	508	575	770	950	177	437	151	372
10"	250 NB	622	622	635	638	912	1190	339	580	288	493
12"	300 NB	698	711	711	727	1010	1290	451	669	384	569

BELLOW SEAL CONTROL VALVES

A Bellows Seal Control Valve is a specialized Globe valve designed to seal valve stem components using bellows. Contained within the valve, the lower end of the stainless-steel or Nickel Alloy bellows is welded to the stem to prevent erosion by the system fluid. The other end is inserted between the valve's body and cover to form a permanent seal. This double seal structure prevents leakage; in the event that the bellows collapse, the stem packaging will prevent further leakage. The bellows are welded to the valve stem to provide steady operation and to eliminate valve stem vibration caused by the valve insert movement.

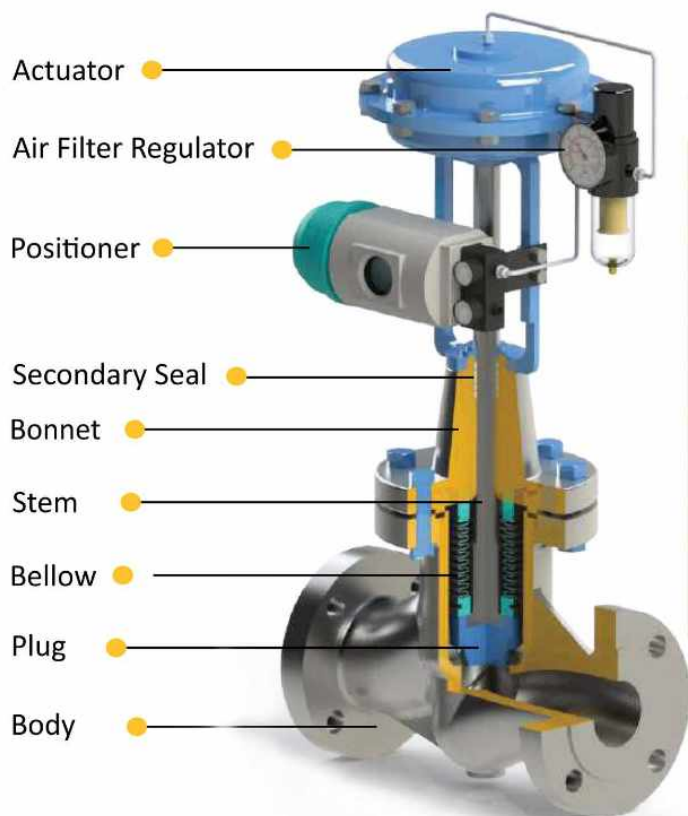

SPECIFICATIONS

End Connection:	Flange (B16.5) / Butt Weld (B16.25)
Size :	15 NB - 600 NB
Pressure Rating:	#150 - #900
Temperature:	190°C to 350°C
MOC :	Carbon Steel / Stainless Steel / Alloy
Design Standard:	MSS SP-117 / API 623
Cycle Life :	3000 - 5000 - 10000 Cycle
Face to Face:	ASME B16.10 Rev 2009
Fire safe design:	API 6FA
Testing:	API 598 Rev 2009 / ISO 15848
Documents:	BS/EN 10204-3.1 REV 2019

Size		Face To Face (F)				Centre Height (H)		Flange Weight (Kg)	
		RF		RTJ					
Inch	NB	#150	#300	#150	#300	#150	#300	#150	#300
1/2"	15NB	-	191	-	-	-	584	-	7
3/4"	20 NB	-	194	-	206	-	660	-	8
1 1/2"	40 NB	222	235	235	248	899	762	18	27
2"	50 NB	254	267	267	283	1025	914	24	31
2 1/2"	65 NB	-	-	-	-	-	-	-	-
3"	80 NB	298	318	311	333	1067	965	43	64
4"	100 NB	352	368	365	384	1245	1092	61	95
6"	150 NB	451	473	463	489	1448	1245	109	195
8"	200 NB	543	568	552	584	1473	1270	171	286
10"	250 NB	673	708	686	724	1822	1295	277	454
12"	300 NB	737	806	749	813	1829	1626	386	697

INDUSTRIES & APPLICATIONS

NUCLEAR & THERMAL POWER



- > Helium
- > Vacuum
- > Heavy Water
- > Hydrogen
- > Uranium
- > High Pressure (H.P) Steam

CHEMICALS & FERTILIZERS (HAZARDOUS MEDIA)

- > Ammonia
- > Hydrogen
- > Phosgene
- > Chlorine
- > Benzene
- > Parathion



REFINERIES & PETROCHEMICALS (HAZARDOUS MEDIA)



- > Naphtha
- > High Temp. Vapours
- > Petroleum Coke
- > Benzene
- > Hydrogen
- > Sulphur
- > Petrochemicals

INDUSTRIES & APPLICATIONS

FOOD & PHARMACEUTICAL INDUSTRIES



- > Vegetable Oils
- > Cyanide Compounds
- > Fatty Acids
- > Steam
- > Oxygen
- > Nitrogen
- > Argon

HEAT TRANSFER MEDIA

- > Hot oil (thermic fluid) is commonly used in industries such as synthetic fibers / POY (Partially Oriented Yarn).
- > It always carries a risk of fire due to hot oil spillage on highly inflammable chemicals.
- > Here, Bellows Seal Valves can prevent spillage. The Bellows Seal Valve is an ideal design, where leakage through the gland is totally eliminated.



VACUUM / ULTRA HIGH VACUUM



- > Some applications require a vacuum pump to continually extract air from a pipeline / jacket.
- > Conventional valves installed on the pipeline can allow external air to enter the pipeline through the valve stuffing box.
- > Hence a Bellows Seal Valve is the ideal solution to prevent the air entry from the stuffing box.

CALCULATION OF CV

DATA FOR CALCULATION OF FLOW AND / OR PRESSURE DROP

$$K_v = C_v \times 0.85$$

$$\frac{m^3/h}{\sqrt{Kg/cm^2}}$$

A Valve coefficient Cv is used to calculate pressure drop through a particular valve for a given flow rate. The coefficient of flow Cv expresses the rate of flow in gallons per minute at 60°F water with a pressure drop of 1 psig across the valve. The Cv coefficients for the various types of sizes, shown in the tables, have been determined from calculations and actual flow test

NOTE: Kv is the metric equivalent of Cv.

FOR LIQUIDS :

$$(1.) \quad Q_L = C_v \frac{\Delta P}{GL}$$

$$(2.) \quad \Delta P = GL \left[\frac{Q_L}{C_v} \right]^2$$

Where QL = Flow in U.S. Gallons per minute

AP (P1-P2) Pressure drop in psi
GL = Specific gravity of liquid (water = 1 at 60°F)

FOR GASES :

$$(3.) Q_g = 1360 C_v$$

CV FLOW COEFFICIENT TABLE

Valve Size Inches	Gate or Bellows Seal Gate Valves Standard Port		Full Port Gate Valves	Globe Valves		Bellows Seal Globe Valves	
	150 - 800	900 - 1500	150 - 1500	150 - 800	150 - 1500	150 - 800	1500 - 2500
1/4"	2.6	2.6	2.6	2	2	1.5	-
1/2"	7	14	14	3	3	2.5	5
3/4	14	14	22	4	4	3.5	7
1	30	30	34	6	8	6	9
1.1/4	85	85	92	14	19	12	30
1.1/2	100	100	110	14	19	12	34
2	160	160	200	33	29	28	38

BELLOW SEAL VALVES & ECONOMICS

CONSIDERING VALVE OF SIZE 3/4" (20NB) #800

A) Capital Cost / Valve:

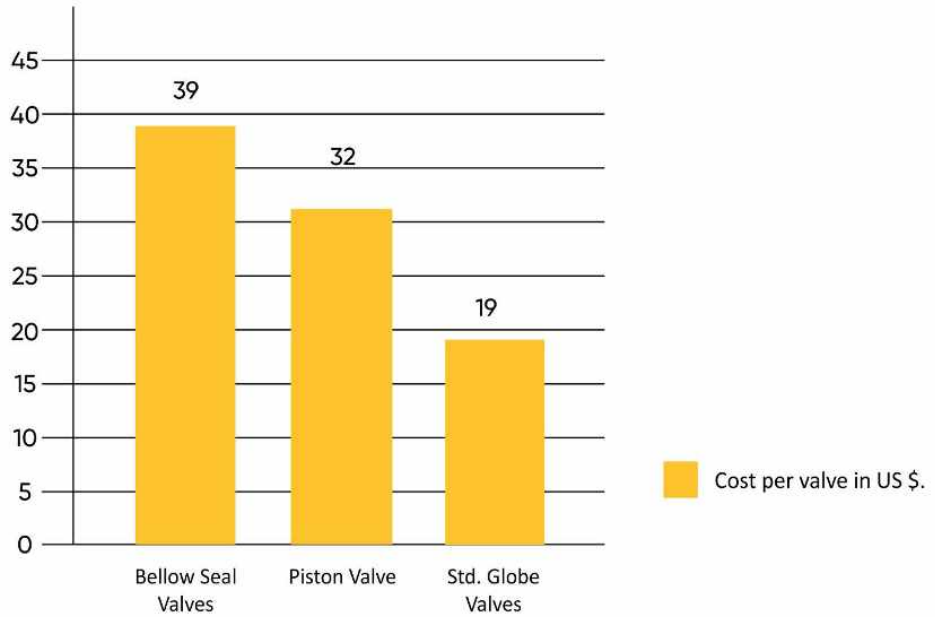

B.1) Maintenance Cost:

Annual Spares Cost per Valve

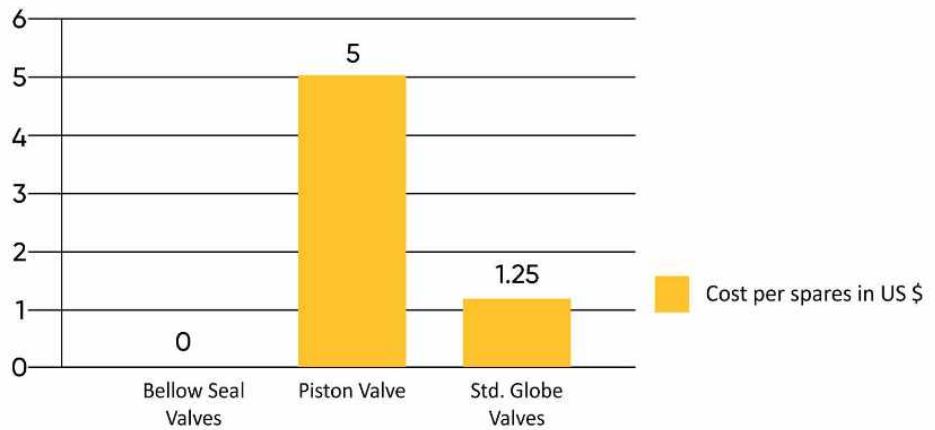

B.2) Maintenance Cost:

Labor Cost / Valve / Year

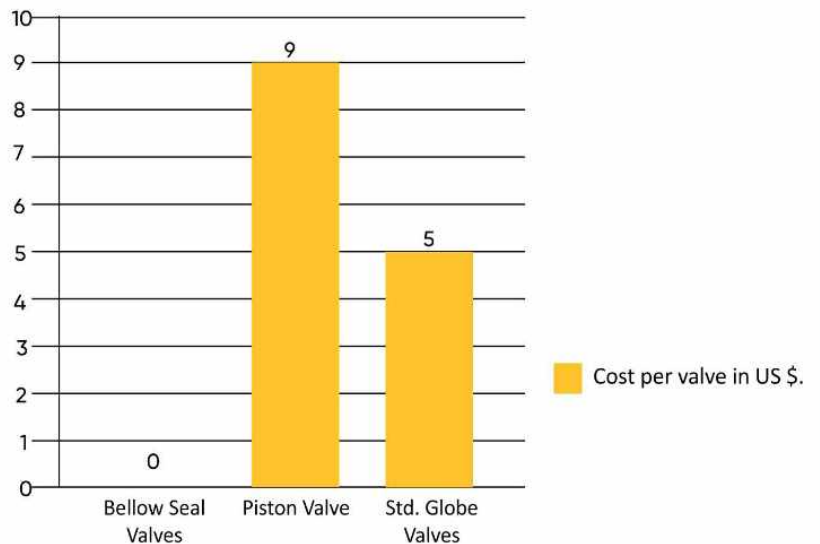

BELLOW SEAL VALVES & ECONOMICS

B.3) Maintenance Cost:

Downtime / Valve / Year

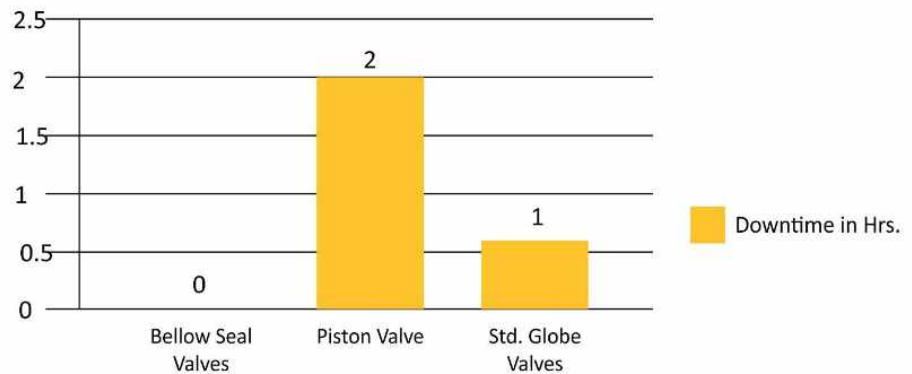

C) Energy or Media Loss / Valve / Year

- > The average Cost of Loss of Media per day is **\$2**.
- > For Piston Valve average leakage will begin in 9 months
\$2 X 90=\$180/year
- > For Standard Globe Valve average leakage will begin in 6 months
\$ 2 X 180 = \$360/year

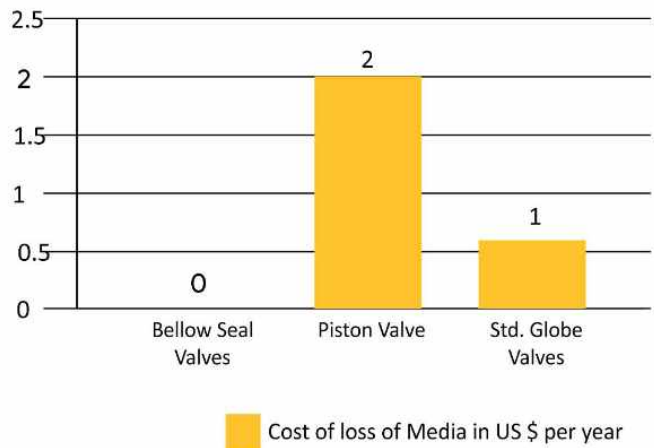

C) Total Cost of Ownership (TCO)= A (Capital Cost)
 +B (Maintenance Cost)
 +C (Cost of Downtime & Energy / Media Loss)

Valve Type	Total Cost (\$)
Bellow Seal Valve	39
Piston Valve	230
Standard Globe Valve	387

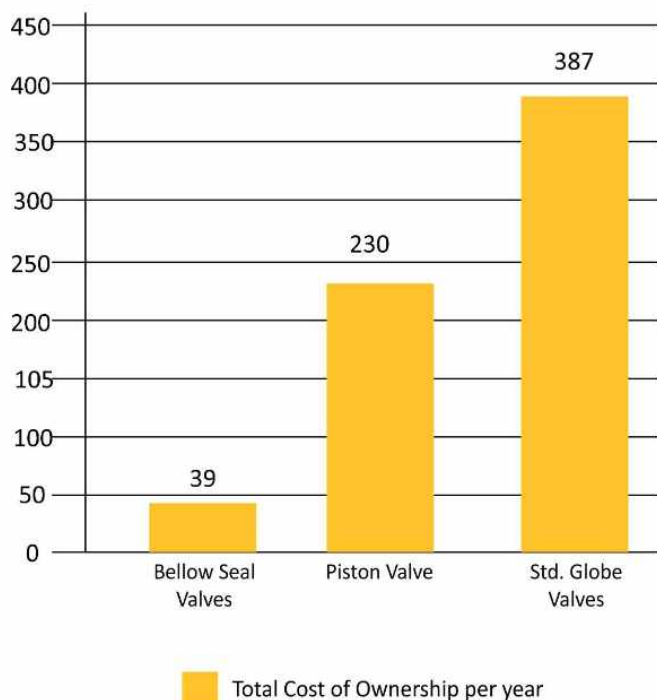

BELLOW SEAL VALVES TESTING







Type Test

The inspection and testing of bellows and bellows assemblies must be divided into two parts: delivery inspection and type inspection. Unless otherwise indicated, the inspection shall be carried out in ambient temperatures ranging from 5 to 40 °C, humidity levels ranging from 20% to 80%, and an air pressure of 86 to 106 kPa. The type test requires 10000 cycles for the cycle test, and the minimum value is used to compute the minimum cycle life. If all three test components are qualified, the type test of this specification's product is qualified. One of the three objects falls short of the mark. If two of the three tests are unqualified, the type test is deemed unqualified as well. It is qualified if there is no leaking of inspection results.

Fugitive Emission Test EN-ISO 15848 - Part 1

The testing of fully assembled valves using suction, flushing, or sniffing (EPA Method 21), depending on the annex utilised and the type and class of the valve. The test fluid is helium or methane, and the standard allows just one change to the valve packing each performance cycle. Valves are normally tested vertically, with horizontal testing available, with cycle speeds determined by the type of valve: isolating or control. For both helium and methane, stem packing leakage is classified into three tightness classes: A, B, and C.

The distinction between helium and methane leaking is unrelated. Tightness class A is the most stringent qualification, with a leak rate of 10⁻⁶ mg/(s*m) during the entire test. The rate for Class B is 10⁻⁴ mg/(sm), whereas the rate for Class C is 10⁻² mg/(s*m). The amount of mechanical cycles is referred to as an endurance class.

SR.NO.		COMPONENT / OPERATION	CHARACTERISTIC CHECKED	TYPE OF CHECK	CLASS	QUANTUM OF CHECK %	REFERENCE DOCUMENT	ACCEPTANCE NORMS	FORMAT OF RECORDS	AGENCY				REMARK (IF)										
										P	W	R	H											
1.0 RAW MATERIAL																								
1.1	Forged & Casting (Body / Bonnet)	Chemical & Physical Analysis	Chemical & Mechanical Prop.	Major	One Sample Per Heat	A216 / A182 / A351 (As Per Client Req.)	A216 / A182 / A351 (As Per ASTM / BS-EN Std.)	(As Mill TC / Lab report from NABL approved.	4	-	1	2	-											
1.2	Trim / Stem / Plug / Wedge	Chemical & Physical Analysis	Chemical & Mechanical Prop.	Major	One Sample Per Heat	A410 / A182 / A105 (As Per Client Req.)	A410 / A182 / A105 (As Per ASTM / BS-EN Std.)	Mill TC / Lab report from NABL approved.	4	-	1	2	-											
1.3	Bellow (Hydra-Witzenmann Germany)	Chemical & Physical Analysis	Chemical & Mechanical Prop.	Major	One Sample Per Heat	SS316 TI / Hst. C 276 (As per Client Req.)	SS316 TI / Hst. C 276 (As per ASTM Std)	Witzenmann 3.1 Report	4	-	1	2	-											
3.0 FINISHED PRODUCT																								
3.1	Shell Test	Hydrostatic & Pneumatic	Body / Seat & Bellow leak	Major	100% FRETURE & Client / TPI	API 598	API 598	Manufacturer TC & EN 10204 3.1C	1	2,3														
3.2	Fugitive Emission Test (If Applicable)	Hydrostatic & Helium Leak Test	Body / Seat & Bellow leak	Major	100% FRETURE & Client / TPI	API 598 / ISO 15848	API 598 / ISO 15848	Manufacturer TC & EN 10204 3.1C	1	2,3														
3.3	Dimension Visual Inspection	Body / Bonnet Physical Diameter	Dimension & Physical Check	Major	100% FRETURE & Client / TPI	Visual Check	Visual Check	TPI / Client Inspector report	1	2,3														
4.0 PACKAGING																								
4.1	Packing & marking	Packing & Labelling	As Per Standard Packing Norms	Minor	100% by FRETURE	As per General packing procedure	As per General packing Manufacturer procedure			1	-	2	-											
5.0 RELEASE NOTE																								
5.1	Inspection release note													2										
<table border="0"> <tr> <td>1. FRETURE Techno</td> <td rowspan="4">  Authorised Signatory Prepared By _____ M/s Freture techno pvt. Ltd </td> <td>P = Performed By</td> <td rowspan="4">  Approved By Client / TPI </td> </tr> <tr> <td>2. Client</td> <td>W = Witnessed By</td> </tr> <tr> <td>3. TPI</td> <td>R = Reviewed By</td> </tr> <tr> <td>4. Vendor</td> <td>H = Hold</td> </tr> </table>															1. FRETURE Techno	 Authorised Signatory Prepared By _____ M/s Freture techno pvt. Ltd	P = Performed By	 Approved By Client / TPI	2. Client	W = Witnessed By	3. TPI	R = Reviewed By	4. Vendor	H = Hold
1. FRETURE Techno	 Authorised Signatory Prepared By _____ M/s Freture techno pvt. Ltd	P = Performed By	 Approved By Client / TPI																					
2. Client		W = Witnessed By																						
3. TPI		R = Reviewed By																						
4. Vendor		H = Hold																						

- Above QAP only for Reference Purpose, final product will be supplied as per approved Drawing & QAP.
- NDT Testing (RT / UT) will be performed as per Client's requirement. (Std. charges applicable)
- Fugitive Emission & any test other than the test mentioned above will cost additional.

FRETURE

EMISSION FREE PROCESS

CLIENTELE



FRETURE TECHNO PVT. LTD.



Fenkin Empire, Kaushalya, Station Road,
Jambli Naka, Thane (W) - 400602.



www.freture.com



+91 75066 82777



sales@freture.com